

Warm-UP: INQUIRY SKILL FOCUS Assessment

Skills Test B: Measure and Calculate

Questions 1–5. Use the diagram below to answer each question. Write your answer on the line at the left.

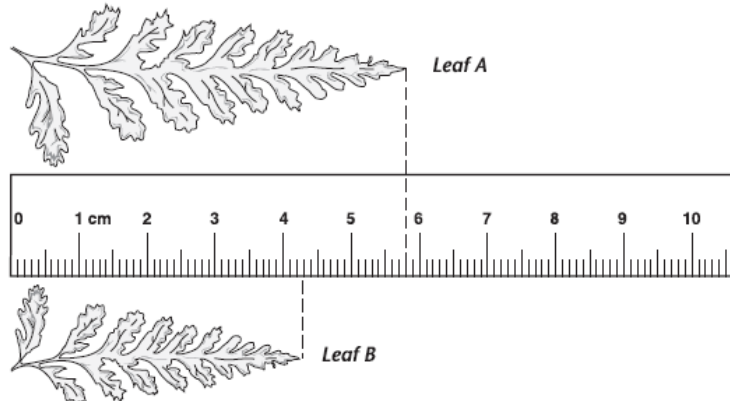

- _____ 1. How many centimeters long is Leaf A?
- _____ 2. How many centimeters long is Leaf B?
- _____ 3. How many centimeters longer is Leaf A than Leaf B?
- _____ 4. How many millimeters long is Leaf A?
- _____ 5. How many millimeters long is Leaf B?

Questions 6–8: Use the diagrams below to answer each question. Write your answer on the line at the left.

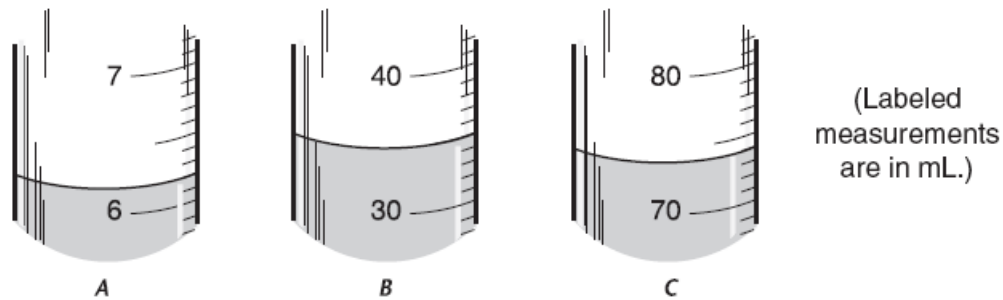

- _____ 6. What is the volume of the water in graduated cylinder A?
- _____ 7. What is the volume of the water in graduated cylinder B?
- _____ 8. What is the volume of the water in graduated cylinder C?

Skills Test B: Measure and Calculate *(continued)*

Questions 9–10: Make the necessary calculations and give your answer in the space below each question.

9. What is the area of the rectangle on the right?

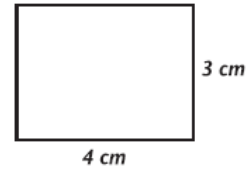

10. What is the volume of the figure on the right?

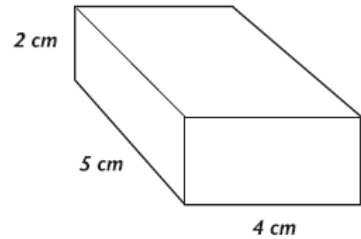

Questions 11-12: Use the information provided and the diagram below to answer the questions. You can show your work below or use the back of this page. Write the answer to each question on the line at the left.

Suppose you need to measure the volume of a small rock. You decide to use water and a graduated cylinder to find that measurement. You obtain the results shown on the right.

- _____ 11. What is the volume of the water plus the rock?
 _____ 12. What is the volume of the rock alone?

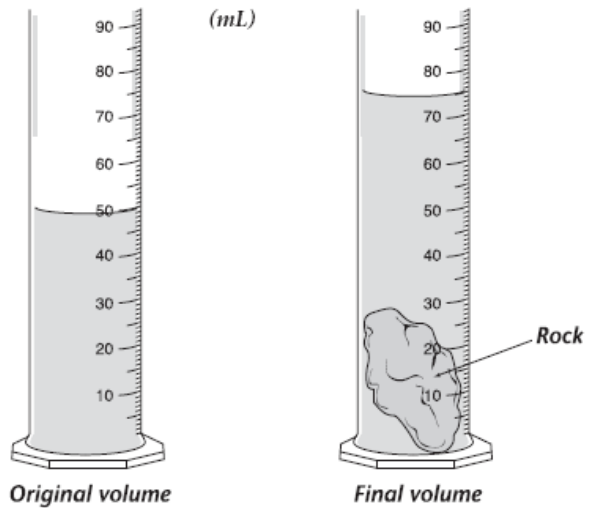

Skills Test B: Measure and Calculate (*continued*)

Questions 13–14: Use the diagram below to answer each question. Write your answer on the line at the left.

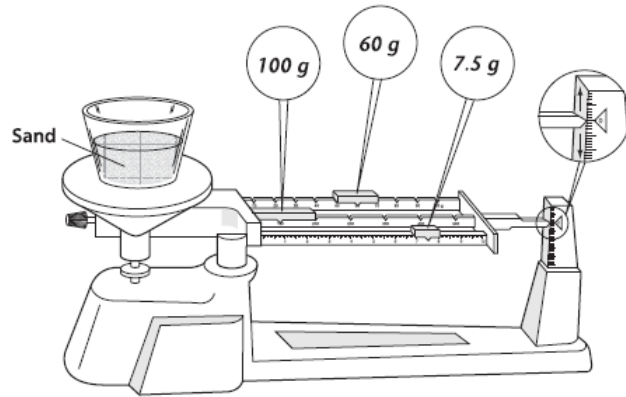

- _____ 13. What is the mass of the container and the sand together?
 _____ 14. If the mass of the container is 14.5 grams, what is the mass of the sand?

Questions 15–19: The diagram below shows five Celsius thermometers. Use these diagrams to answer each question. Write your answer on the line at the left.

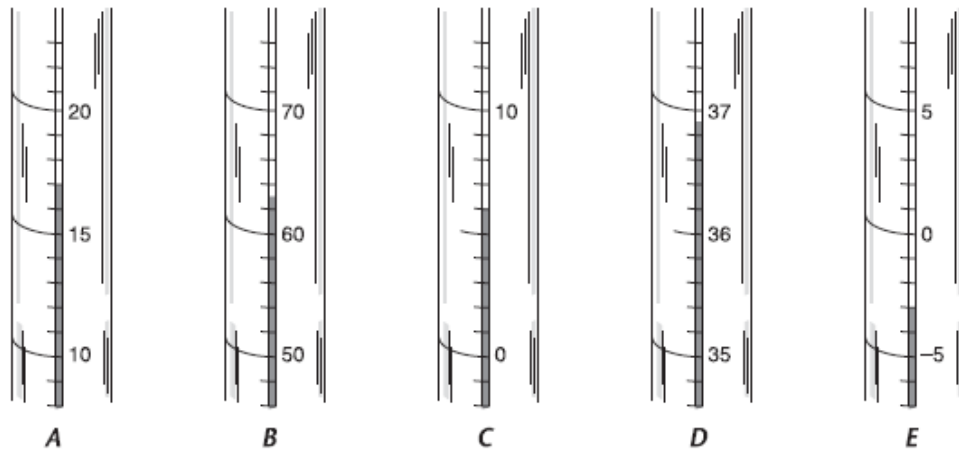

- _____ 15. What is the temperature on Thermometer A?
 _____ 16. What is the temperature on Thermometer B?
 _____ 17. What is the temperature on Thermometer C?
 _____ 18. What is the temperature on Thermometer D?
 _____ 19. What is the temperature on Thermometer E?

Skills Test B: Measure and Calculate (*continued*)

Questions 20–21: The diagram below shows a Celsius thermometer on different days. Use the diagram to answer each question. Write your answer on the line at the left.

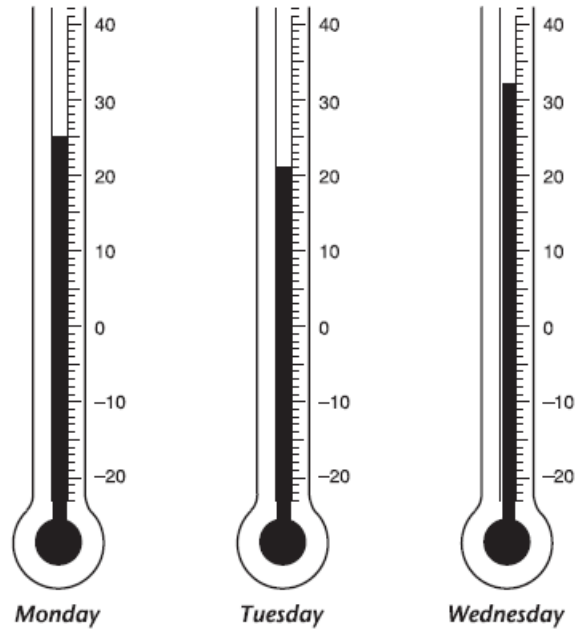

_____ 20. What was the decrease in temperature from Monday to Tuesday?

_____ 21. What was the increase in temperature from Tuesday to Wednesday?

Questions 22–25: Convert between the following SI units. Show all your work. Write your answer on the line at the left.

_____ 22. 34.0 kilograms = _____?_____ grams

_____ 23. 30.0 meters = _____?_____ centimeters

_____ 24. 250 milliliters = _____?_____ liters

_____ 25. 4,500 meters = _____?_____ kilometer